

G-SERIES LPG & GASOLINE FORKLIFT 3.0-3.5 TON

General	1	Model		FY30	FY35		
	2	Power Type		LPG & Gasoline	LPG & Gasoline		
3	Rated Capacity		kg	3000	3500		
4	Load Centre		mm	500	500		
5	Lift Height		mm	3000	3000		
Characteristic&Dimension	6	Fork Size	L×W×T	mm	1070×125×45	1070×125×50	
	7	Mast Tilt Angle	F/R	Deg	6°/12°	6°/12°	
	8	Front Overhang (Wheel center to fork face)		mm	475	480	
	9	Ground Clearance (Bottom of mast)		mm	135	135	
	10	Overall Dimension	Length to face of fork(Without fork)		mm	2730	2770
			Overall Width		mm	1225	1225
			Mast Lowered Height		mm	2115	2115
			Mast Extended Height(With backrest)		mm	4160	4160
			Overhead Guard Height		mm	2090	2090
	15	Turning Radius (outside)		mm	2440	2480	
16	Min. insecting aisle		mm	2490	2530		
Performance	17	Speed	Travel (Empty load)	km/h	19	19	
	Lifting(Full load)		mm/s	440	420		
	19	Max.Gradeability		%	20	20	
Chassis	20	Tire	Front	28×9-15-12 PR			
	21		Rear	6.50-10-10 PR			
	22	Wheelbase		mm	1700	1700	
	23	Service weight		kg	4300	4500	
Power&Transmission	24	Battery	Voltage/Capacity	V/Ah	12/80	12/80	
	25	Engine	Model		K25		
	26		Manufacture		NISSAN		
	27		Rated output/r.p.m.		kw	37.4 / 2300	
	28		Rated torque/r.p.m.		N·m	176.5 / 1600	
	29		No.of Cylinder		4		
	30		Bore×Stroke		mm	89 × 100	
	31		Displacement		cc	2488	
	32		Fuel Tank Capacity		L	60	60
	33	Transmission	Type		Hydraulic		
34	Stage		FWD/RVS	1/1	1/1		
35	Operating Pressure for Attachment		Mpa	17.5	17.5		

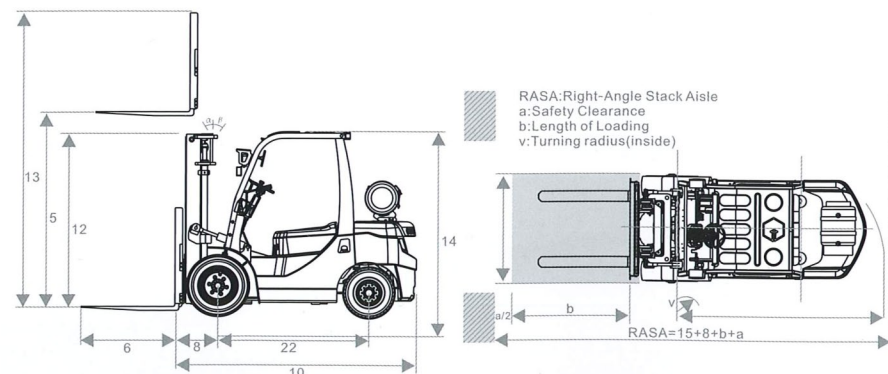
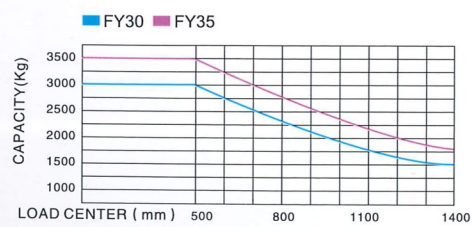

G-SERIES 3.0-3.5 TON LPG & GASOLINE FORKLIFT MAST

Type	Model	Lift Height (mm)	Load Capacity (kg)		Overall Height (mm)						Free Lift (mm)				Tilt Angle F/R(deg)
					3.0t			3.5t			3.0t		3.5t		
					Mast Lowered	With Backrest	Without Backrest	Mast Lowered	With Backrest	Without Backrest	With Backrest	Without Backrest	With Backrest	Without Backrest	
Wide view 2-stage mast	M200	2000	3000	3500	1615	3180	2720	1615	3180	2720	-	-	-	-	6/12
	M250	2500	3000	3500	1865	3680	3220	1865	3680	3220	-	-	-	-	6/12
	M300	3000	3000	3500	2115	4180	3720	2115	4180	3720	-	-	-	-	6/12
	M330	3300	3000	3500	2265	4480	4020	2265	4480	4020	-	-	-	-	6/12
	M350	3500	3000	3500	2365	4680	4220	2365	4680	4220	-	-	-	-	6/12
	M370	3700	3000	3500	2465	4880	4420	2465	4880	4420	-	-	-	-	6/12
	M400	4000	2950*3000	3200*3500	2665	5180	4720	2665	5180	4720	-	-	-	-	6/12
	M450	4500	2750*3000	3000*3050	2915	5680	5220	2915	5680	5220	-	-	-	-	6/6
	M500	5000	2400*2500	2500*2850	3165	6180	5720	3165	6180	5720	-	-	-	-	6/6
	M550	5500	2250*2400	2300*2500	3465	6680	6220	3465	6680	6220	-	-	-	-	3/6
M600	6000	1500*2200	1800*2300	3715	7180	6720	3715	7180	6720	-	-	-	-	3/6	
Full free 2-stage mast	Z200	2000	3000	3500	1615	3180	2720	1615	3180	2720	470	930	470	930	6/12
	Z250	2500	3000	3500	1865	3680	3220	1865	3680	3220	720	1180	720	1180	6/12
	Z300	3000	3000	3500	2115	4180	3720	2115	4180	3720	970	1430	970	1430	6/12
	Z330	3300	3000	3500	2265	4480	4020	2265	4480	4020	1120	1580	1120	1580	6/12
	Z350	3500	3000	3500	2365	4680	4220	2365	4680	4220	1220	1680	1220	1680	6/12
	Z370	3700	3000	3500	2465	4880	4420	2465	4880	4420	1320	1780	1320	1780	6/12
	Z400	4000	2900*3000	3300*3500	2665	5180	4720	2665	5180	4720	1520	1980	1520	1980	6/12
	S370	3700	2900	3300	1870	4875	4420	1870	4875	4420	730	1185	730	1185	6/6
Full free 3-stage mast	S400	4000	2900	3300	1970	5175	4720	1970	5175	4720	830	1285	830	1285	6/6
	S435	4350	2800*2900	3000*3300	2085	5525	5070	2085	5525	5070	945	1400	945	1400	6/6
	S450	4500	2700*2800	2900*3100	2135	5675	5240	2135	5675	5240	995	1450	995	1450	6/6
	S480	4800	2500*2800	2700*3000	2235	5975	5520	2235	5975	5520	1095	1550	1095	1550	6/6
	S500	5000	2300*2550	2500*2800	2305	6175	5720	2305	6175	5720	1165	1620	1165	1620	6/6
	S550	5500	2200*2400	2350*2500	2520	6675	6220	2520	6675	6220	1385	1840	1385	1840	3/6
	S600	6000	1500*2100	1650*2200	2685	7175	6720	2685	7175	6720	1550	2010	1555	2010	3/6

G-SERIES
3.0-3.5Ton
LPG & GASOLINE
FORKLIFT

